

MASTER GRAVITY



Compact, comfortable,
Quiet and competitive

With its **damped, gravity-driven, tip-up seat base**, Master Gravity minimises maintenance costs and ensures extremely quiet operation.

Compatible with restrictive spaces, its compact design allows to fit more seating positions in a given space.

With Master Gravity, comfort and lifespan are improved, thanks to a higher, double-curved moulded backrest and a silent movement.

With new production processes and thanks to the use of moulded foam, today, Master Industrie goes even further in offering high-quality seating solutions, with numerous assets, at competitive pricing.



MASTER GRAVITY
Is entirely designed and
product in France



*See terms and conditions
Warranty

FEATURES

For use as follows: Chair with hinged seat folding down forwards on stand (Rear mounted)/Mounted on moveable beam / Attached to the floor.

Operation: manual or automatic

Attachment System: On stand (2 self-tapping screws on the structure + 4 hinge screws on the floor). On the floor (mechanical anchors and screws suitable for the surface).

Seat Folding Mechanism: Gravity-driven.

The MASTER Gravity chair complies with local fire regulations.

METAL FRAME

Tubular frame made using robot-assisted mechanical welding from laser-cut parts and machined pins for greater precision and an improved finish.

Protective Coating: Thermosetting paint. Standard colour: Black (RAL 9005).

Other colours available, upon request.

BACKREST/SEAT

Metal structures built into the backrest and seat, and hinged on the chair's metal frame.

Wood frame made of beech plywood, 15mm thick, shaped over the entire width. Upon request.

Comfortable, high-resilience moulded polyurethane foam, density 42 kg/m³, glued to the wood frame.

Removable fabric cover with zip. Double-stitched cover on the front of the backrest and the upper side of the seat cushion, for an elegant finish.

Optional double-stitched cover on the front of the backrest and the upper side of the seat cushion, for an elegant finish.

Foam-backed fabric, 6 mm thick.

Automatic lifting (gravity-driven).

ARMESTS

Laser-cut and robot-assembled hinged **metal frame**.

Automatic lifting (gas-assisted).

Stained, varnished solid **wood armrest**.

OPTIONS

Choice of fabrics.

Wooden casing behind the backrest and under the seat.

Numbering.

Upholstered armrest.

MASTER Gravity S: any specific shape or dimension, cut foam.

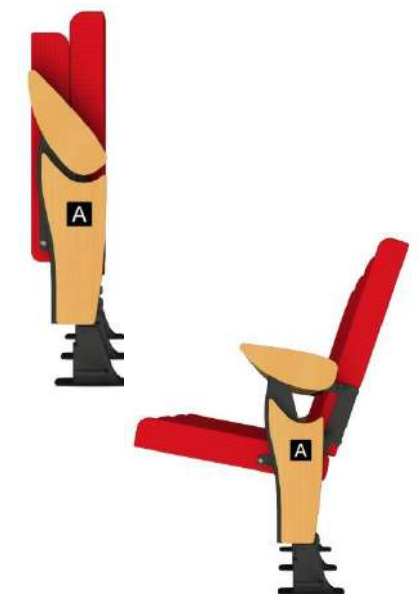

MASTER
INDUSTRIE

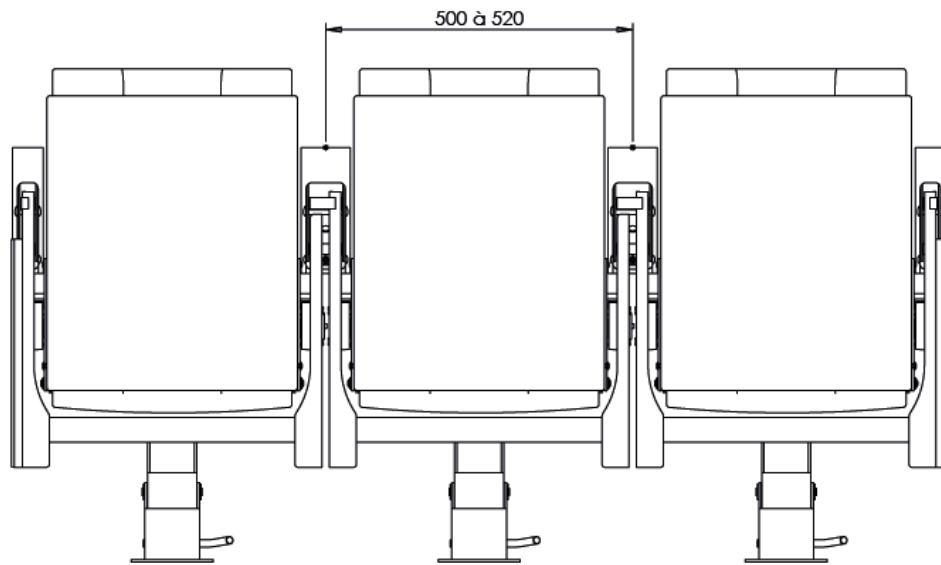

Master Gravity S: any specific dimension

